

## Picture



## Feature

Miniature size 42.3mm\*42.3mm\*13.5mm (L\*W\*H)  
 Integrally designed to fit onto motors seamlessly, as well as work standalone  
 Wide range input voltage 10-40VDC  
 Max 2A / 4A / 8A adjustable output current  
 1 to 16th micro step resolution  
 Dual full H-bridge with PWM constant current control  
 Enable/shutdown input for power saving  
 Optoisolated inputs with common anode  
 Die-cast aluminum enclosure, improve heat radiation and durability

**MACH 3 Compatible**

## Description

CI240 Miniature Stepper Motor Controller is a series of miniature, high performance stepper motor controller. They can be mounted onto H42 / H57 / H86 / H110 (NEMA17, NEMA23, NEMA34, NEMA42) series stepper motor seamlessly through corresponding flanges. The thickness of these controllers is less than 14 mm.  
 CI240-2A is capable to provide 0-2A adjustable current, 10~35VDC  
 CI240-4A is capable for 1.6-4A adjustable current output , 12~40VDC  
 CI240-8A is capable for 2A-8A adjustable current, 12~40VDC  
 Their mixed-decay current control reduces the back-EMF effect under high motor speed and improves the performance. The cover is made of die-cast aluminum which provides a rugged durable protection and improves the heat dissipation

## Optically Isolated Input Interface

CI240xx controllers' logic control inputs are all optically isolated. All opto-couplers share one common anode (Vcc) as shown in above schematic diagram. Typically, Vcc is 5V. However, 3.3V or voltages higher than 5V are also acceptable, so long as the current through the opto-coupler's emitter is between 5~20mA

Should a voltage higher than 5V be applied to Vcc, an additional resistor is needed for every terminal to ensure that the current through each emitter does not exceed 20mA

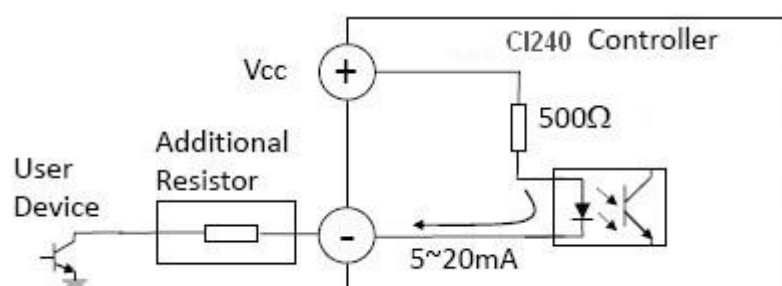

## Terminal Description

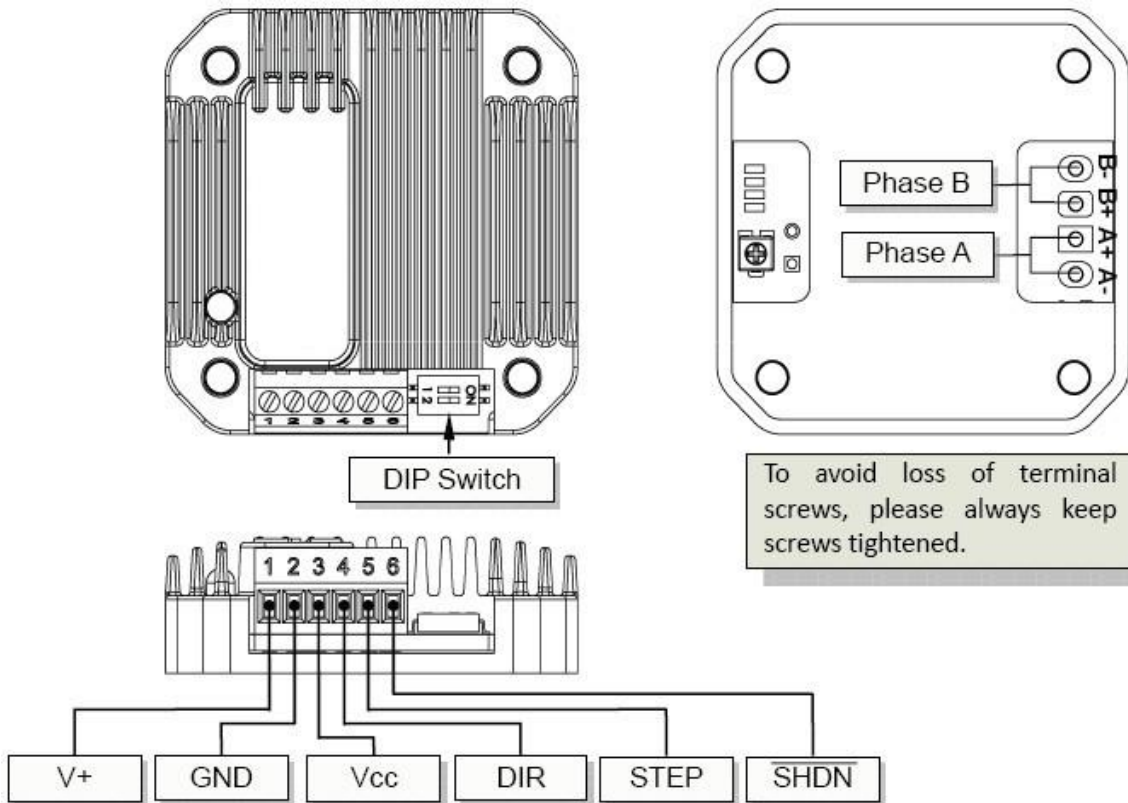

### SCREW TERMINAL

Terminal No./ Color		Description		MIN.	MID	MAX.	UNIT
1/Red	V+	Supply voltage	CI240-4A/8A	12		40	VDC
			CI240-2A	10		35	
2/Black	GND	Supply voltage ground			0		VDC
3/White	Vcc	Opto-coupler common anode			5(1)		VDC
4/Green	DIR	Direction input(2)		GND		Vcc	VDC
5/Blue	STEP	Stepping pulse input(3)		GND		Vcc	VDC
6/Yellow	SHDN	Shut down the controller(4)		GND		Vcc	VDC

Note:

- (1) Please refer to "optically isolated input interface" section for details.
- (2) Input is considered high level if this terminal is not connected.
- (3) Low-level pulse duration should be Maximum pulse frequency is 50KHz.
- (4) An active low-level input shuts down power supply to the motor. High-level input or left open makes the controller fully working. When asaken from shutdown mode, wait 1 millisecond before sending pulse

### MOTOR WIRING PADS

**Pad A + / A-** (at the bottom of the controller): Connect to the stepper motor phase A

**Pad B + / B-** (at the bottom of the controller): Connect to the stepper motor phase B



Note: To avoid damaging the controller, make sure the phase winds are connected correctly. Resistance between leads of different phases is usually > 100kΩ. Resistance between leads of the same phase is usually < 100Ω

### Typical Application

CI240 controller's wiring is very straightforward as shown in following Figure. Terminal 6 (SHDN) can be left open if offline is not needed.

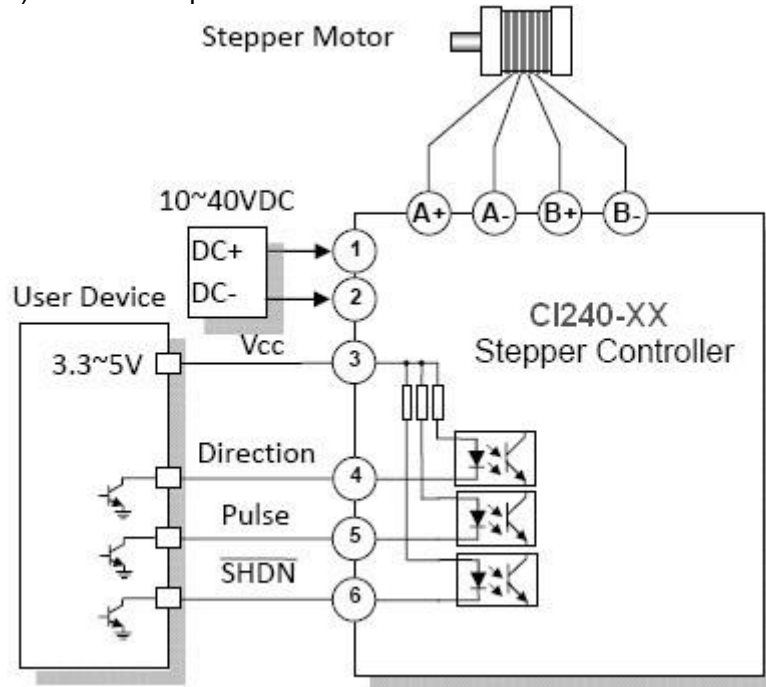

### Mechanical Dimensions

Unit :mm

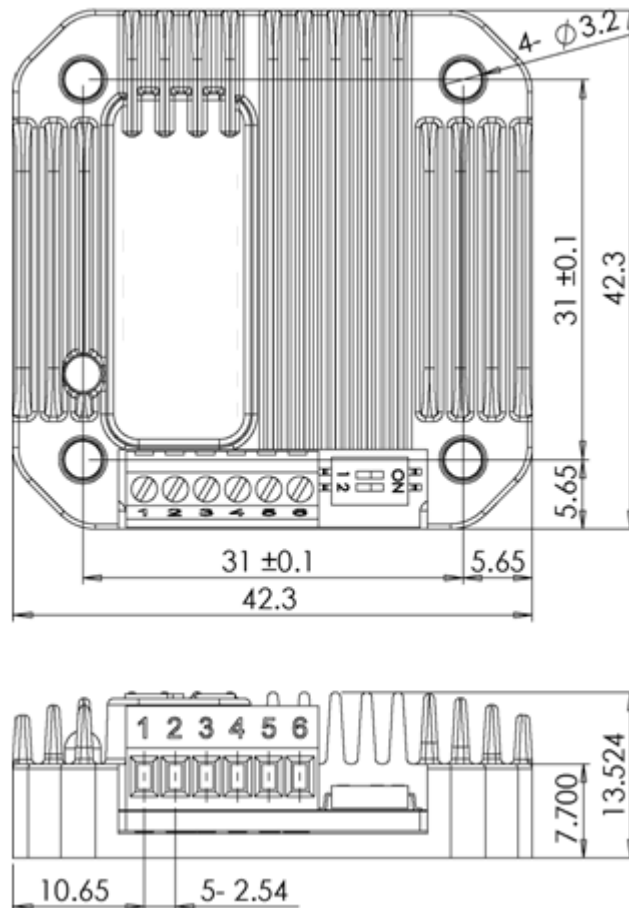

## Characteristic

### Absolute Maximum Ratings

Supply Voltage	40VDC (CI240-2A is 35VDC)
Store Temperature	-40°C ~ +125°C
Working Temperature	-20°C ~ +85°C

Working under environment exceeding maximum value could damage the controller

### Electrical Characteristics (Ambient Temperature 25°C)

Supply Power Voltage	10V~ 40VDC (CI240-2A is 8V~ 35VDC)
Motor Output Current	Max 2A/4A/8A per phase(Adjustable through on-board trimmer)
Driving Mode	PWM constant current
Stepping Resolution	Full-step,half-step,quarter-step,and sixteenth-step
Insulation Resistance	>100MΩ
Dielectric Strength	0.5KV in one minute

### Communication(Ambient Temperature 25°C)

Parallel Communication	3-wireinterface: Pulse, Direction, Shutdown
Micro Step Resolution	1,2,4,16 set through on-board DIP switch

### Environment Requirements

Cooling		Free Air
Working Environment	Environment	Avoid dust, oil mist and corrosive gases
	Temperature	-20°C ~+85°C
	Humidity	<80%RH, n condensation, no frosting
	Vibration	3GMax
Storage Temperature		-40°C ~+125°C

### Size and Weight

Size	42.3mm X 42.3mm X 13.5mm (L*W*H)
Weight	0.1kg

## Function Description

### Supply Voltage

CI240 controllers accept a wide range input voltage from 12 to 40VDC. (CI240-2A accepts 10~35VDC) In general, higher supply voltage improves motor performance under high speed situation, but also increases the power loss and temperature raise.

### Adjust Output Current

CI240-2A / CI240-4A / CI240-8A are capable of providing 2A / 4A / 8A per phase maximum output current respectively. In specific application, the peak output current needs to be adjusted to meet the rated motor current. A trimmer (potentiometer) is provided to serve this purpose at the bottom of the controller, as shown in the following figure. Measuring the mapped voltage ( $V_a$ ) when tuning the trimmer provides an easy way to set the output current.

For UIM24002, a mapped voltage of 0 - 4V proportionally represents 0 ~ 2A. For CI240-4A, a mapped voltage of 0 - 4V proportionally represents 1.5 ~ 4A. For UIM24008, a mapped voltage of 0 - 4V proportionally represents 3.0~8A

Please note that the controller needs to be powered before the mapped voltage  $V_a$  can be measured. (The motor is not required to be connected at this time)

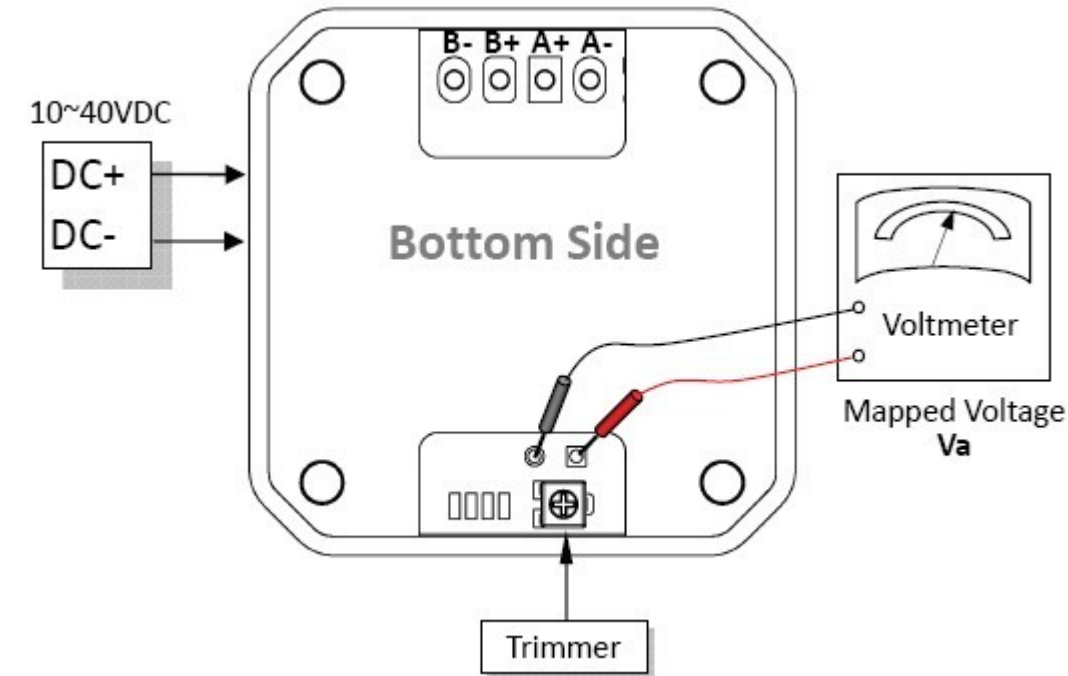

Note:  $V_a$  exceed 4V will be internally clamped to 4V.  $V_a$  higher than 4V will increase the power consumption and temperature.

### Set Micro Step Resolution

The micro step resolution is set by the DIP switch as shown in following figure

UIM240xx controller can provide complete micro-stepping control at full-step, half-step, quarter-step, and sixteenth-step resolution

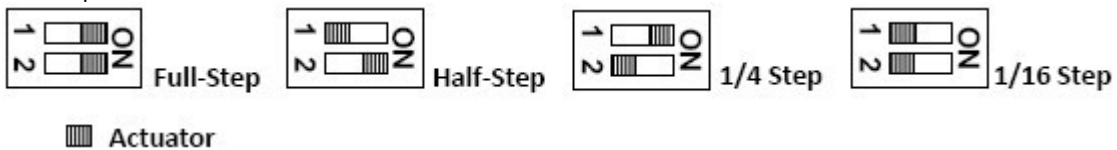

## Installation

