



### GENERAL FEATURES

- Able to operate at 60°C
- Integrated design to ensure the best uniformity and reliability
- Longer Service Life and high stability under high temp. (no air-con needed)
- Use special additives:  
Deep discharge recovery capability

### APPLICATIONS

- BTS Stations
- Solar & Wind energy system
- UPS system
- Telecom systems
- Power Plants
- Cable TV Systems

### DIMENSIONS & WEIGHT

Length(mm)	241±1
Width(mm)	171±1
Height(mm)	329±1
Total Height(mm)	365±1
Weight(kg)	31.2±3%

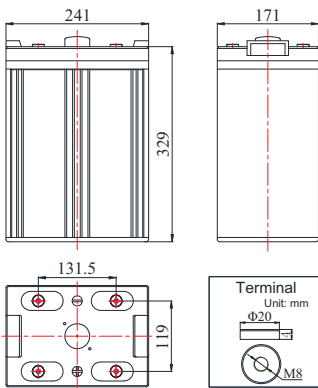

### COMPLIED STANDARDS

IEC 60896-21/22	JIS C8704
YD/T1360	BS6290 part4
GB/T 19638	UL 1989

### TECHNICAL SPECIFICATIONS



Nominal Voltage		2V(1 cells per unit)
Design Floating Life @25°C		18 Years
Nominal Capacity @25°C (10 hour rate@50.0A,1.8V)		500Ah
Capacity @25°C	20 hour rate (26.5A,1.8V)	530Ah
	5 hour rate (88.0A,1.75V)	440Ah
	1 hour rate (320.5A,1.6V)	320.5Ah
Internal Resistance	Full Charged Battery@25°C	≤0.57mΩ
Ambient Temperature	Discharge	-30°C~60°C
	Charge	-30°C~60°C
	Storage	-30°C~60°C
Max.Discharge Current@25°C		2500A(5s)
Capacity affected by Temperature (10 hr Capacity )	40°C	108%
	25°C	100%
	0°C	90%
	-15°C	70%
Self-Discharge@25°C per Month		3%
Charge (Constant Voltage) @25°C	Standby Use	Initial Charging Current Less than 75A Voltage 2.23-2.27V
	Cycle Use	Initial Charging Current Less than 75A Voltage 2.33-2.37V

### BATTERY DISCHARGE TABEL

#### Discharge Constant Current per Cell (Amperes at 25°C)

F.V/Time	30min	45min	1h	2h	3h	4h	5h	6h	8h	10h	20h
1.60V	531.5	402.5	320.5	187.5	143.0	111.0	93.0	81.0	65.0	52.5	27.75
1.65V	503.5	387.0	310.0	181.5	138.5	108.5	91.5	79.5	64.5	51.5	27.50
1.70V	489.0	373.0	301.5	176.5	135.0	106.0	89.5	78.0	63.5	51.0	27.20
1.75V	467.5	356.5	290.5	172.0	132.0	103.5	88.0	76.5	63.0	50.5	26.95
1.80V	450.5	343.5	280.5	165.5	128.0	101.0	86.0	75.0	61.0	50.0	26.50

#### Discharge Constant Power per Cell (Watts at 25°C)

F.V/Time	30min	45min	1h	2h	3h	4h	5h	6h	8h	10h	20h
1.60V	1025.5	764.5	617.0	355.5	273.5	213.0	179.5	156.5	128.0	102.5	54.5
1.65V	979.5	738.5	600.5	346.0	266.5	209.0	176.5	154.0	127.0	101.5	53.5
1.70V	938.0	715.0	580.0	338.0	260.5	205.0	174.0	152.0	125.0	100.5	53.0
1.75V	891.5	686.5	559.0	330.0	255.5	200.5	171.5	149.5	122.0	99.5	52.5
1.80V	854.0	663.5	541.0	319.0	248.5	196.0	168.0	147.0	119.5	99.0	52.0

**Note** The above data are average values, and can be obtained within 3 charge/discharge cycles. These are not minimum values. Cell and battery designs/specifications are subject to modification without notice. Contact **CBB** for the latest information.

### PERFORMANCE CHARACTERISTICS

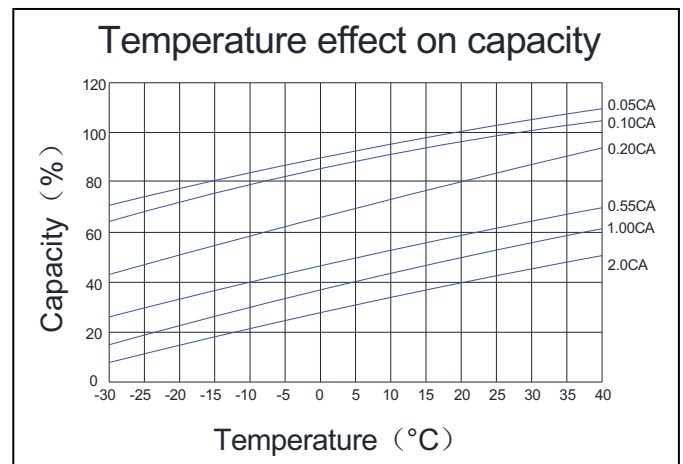
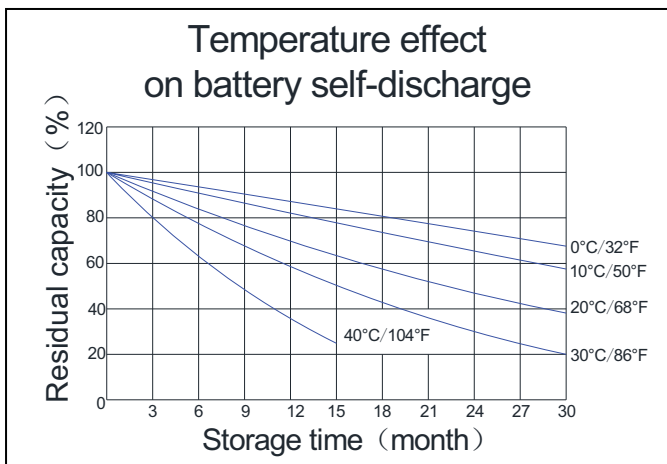
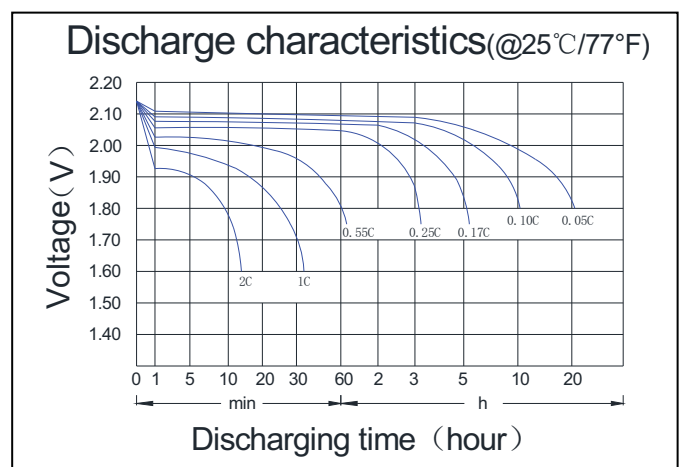
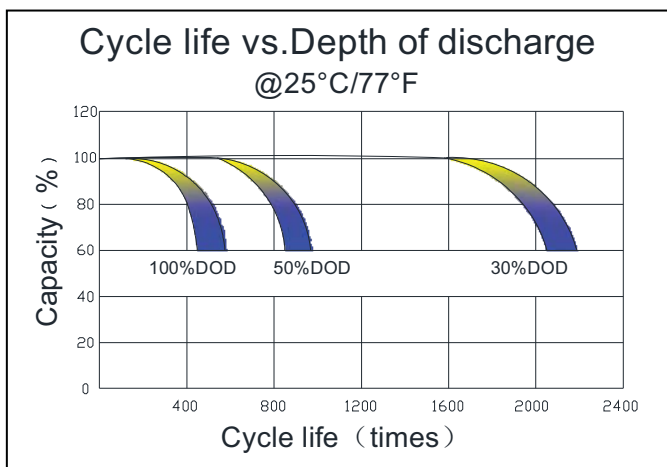
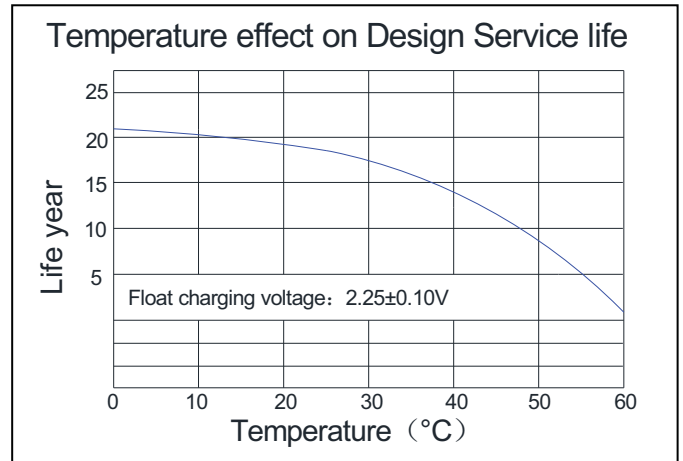
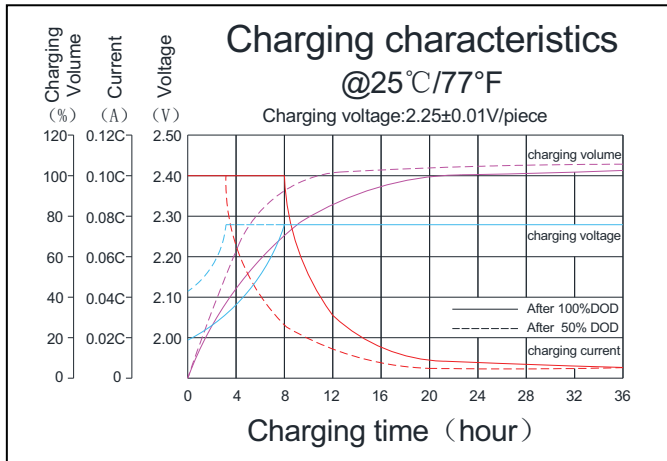

### BATTERY CONSTRUCTION

Component	Positive plate	Negative plate	Container & Cover	Safety valve	Terminal	Separator	Electrolyte	Pillar seal
Features	Thick high Sn low Ca grid with special paste	Balanced Pb-Ca grid for improved recombination efficiency	ABS (UL94-V0 optional)	Flame Si-Rubbeand aging resistancer	Female Copper Insert M8 (torque: 1 0~12N.m)	Advanced AGM separator for high pressure cell design	Dilute high purity sulphuric acid with fumed Silica gel	Two layers epoxy resin seal

**CBB Battery Technology Co., Ltd.**

RM504,55 Hanxing Zhong Road,Zhongcun, Panyu,Guangzhou 511495 China

Tel: +86-020-84888946 Fax: +86-020-62824569

Copyright©2017 CBB Battery Technology Co., Ltd.

# Koyama®

www.cbb-battery.com