



for

LED



GooLED

GooLED-LUME-7830 Pin Fin Heat Sink Φ 78mm for Lumens

Features VS Benefits

- * The GooLED-LUME-7830 Lumens Pin Fin LED Heat Sinks are specifically designed for luminaires using the Lumens LED engines.
- * Mechanical compatibility with direct mounting of the LED engines to the LED cooler and thermal performance matching the lumen packages.
- * For spotlight and downlight designs from 1,000 to 2,700 lumen.
- * Thermal resistance range Rth 3.03°C/W.
- * Modular design with mounting holes foreseen for direct mounting of Lumens Ergon COB series, and AC-ALL series LED engines.
- * Diameter 78.0mm - standard height 30.0mm Other heights on request.
- * Forged from highly conductive aluminum.



Zhaga LED engine and radiator assembly is a unified future international standardization

- * Below you find an overview of Lumens COB's and LED modules which standard fit on the Pin Fin LED Heat Sinks.
- * In this way mechanical after work and related costs can be avoided, and lighting designers can standardize their designs on a limited number of LED Pin Fin LED Heat Sink.

LUMENS

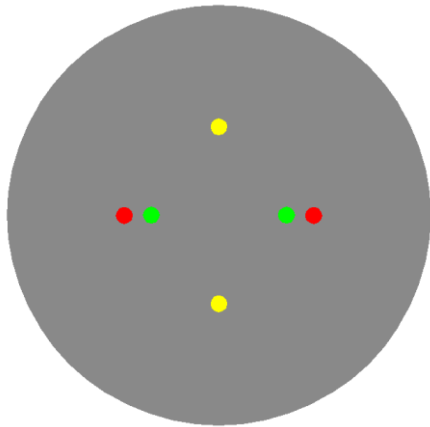

Lumens LED Modules directly Mounting Options

Lumens Ergon COB_HO, COB_HO+, COB_HE Series :

- ERC1812xxxxHO; ERC1812xxxxHE;
- ERC1820xxxxHO; ERC1820xxxxHE;

With the Zhaga Book 3 holders for the red indicator marks.
(Ideal Holder:50-2101CR); (BJB holder:47.319.2131.50);
Without the holders for the green indicator marks.
Direct mounting with machine screws M3x6.5mm.

Lumens Ergon COB_HO, COB_HO+, COB_HE Series :

- ERC2520xxxxHO; ERC2530xxxxHE;
- ERC2530xxxxHO; ERC2540xxxxHE;
- ERC2540xxxxHO; ERC2530xxxxHO+
- ERC2520xxxxHO+

With the Zhaga Book 3 holders for the red indicator marks.
(Ideal Holder:50-2102CR); (BJB Holder:47.319.2141.50);
Without the holders for the yellow indicator marks.
Direct mounting with machine screws M3x6.5mm.

Lumens AC-ALL Series :

- EDC/47C/15W/xxx/120V/B; EDC/47C/15W/xxx/230V/A;
- EDC/57C/20W/xxx/120V/B; EDC/57C/20W/xxx/230V/A;
- EDC/57C/30W/xxx/120V/B; EDC/57C/30W/xxx/230V/A;

With the Zhaga Book 3 holders for the red indicator marks.
Direct mounting with machine screws M3x6.5mm.

Please refer to the www.lumensleds.com data provided on the manual.



Mounting Options and Drawings & Dimensions

Example:GooLED-LUME-7830-B-1,2

Example:GooLED-LUME-78 **1** - **2** - **3**

- 1** Height (mm)
- 2** Anodising Color
B-Black
C-Clear
Z-Custom
- 3** Mounting Options - see graphics for details Combinations available
Ex.order code - 12
means option 1 and 2 combined

Notes:

- Mentioned models are an extraction of full product range.
- For specific mechanical adaptations please contact MingfaTech.
- MingfaTech reserves the right to change products or specifications without prior notice.

MOUNTING OPTION	Module type	Holder NO.	THREAD	THREAD DEPTH	THREAD HOLE DISTANCE
1	Ergon COB (17.85x17.85)	/	M3	6.5mm	25.0mm/ 2-@180°
2	Ergon COB (23.85x23.85)	/	M3	6.5mm	33.0mm/ 2-@180°
3	AC-ALL Series	Lumens	M3	6.5mm	35.0mm/ 2-@180° (Zhaga book 3)
	Ergon COB (17.85x17.85)	BJB Holder 47.319.2131.50			
		Ideal Holder 50-2101CR			
	Ergon COB (23.85x23.85)	BJB Holder 47.319.2141.50			
Ideal Holder 50-2102CR					

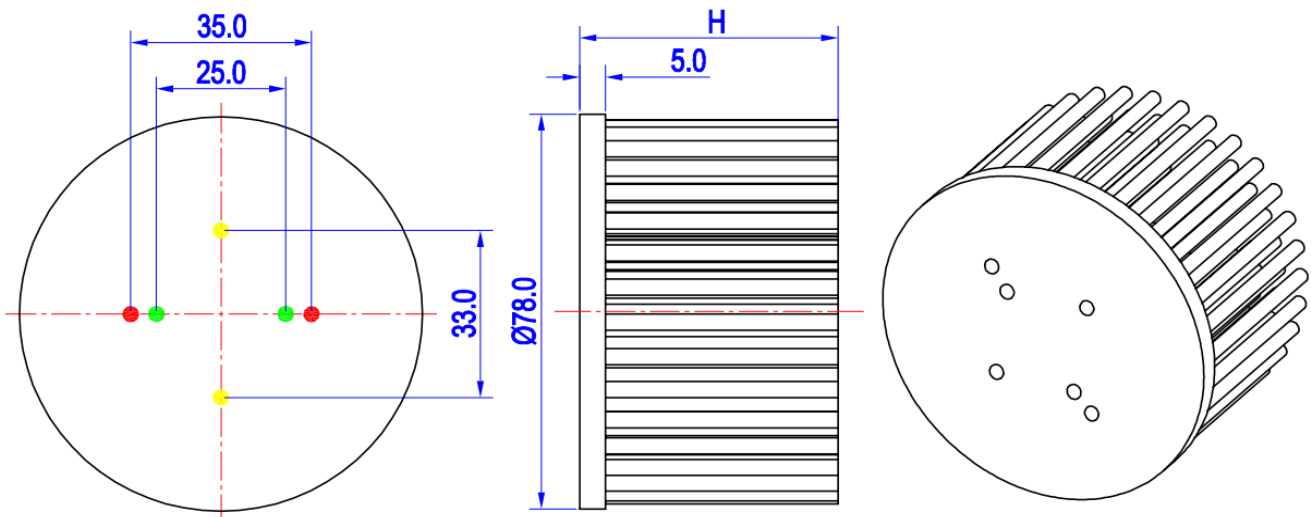

GooLED

GooLED-LUME-7830 Pin Fin Heat Sink Φ 78mm for Lumens

The product data table

	Model No.	GooLED-LUME-7830
	Heatsink Size	Φ 78xH30mm
	Heatsink Material	AL1070
	Finish	Black Anodized
	Weight (g)	138.0
	Dissipated power (T _{hs-amb} ,50°C)	16.5 (W)
	Cooling surface area (mm ²)	46643
	Thermal Resistance (R _{hs-amb})	3.03 (°C/W)

The thermal data table

* Please be aware the dissipated power Pd is not the same as the electrical power Pe of a LED module.

*To calculate the dissipated power please use the following formula: Pd = Pe x (1-ηL).

Pd - Dissipated power ; Pe - Electrical power ; ηL = Light efficiency of the LED module;

Dissipated Power Pd(W)	Pd = Pe x (1-ηL)	Heat sink to ambient thermal resistance R _{hs-amb} (°C/W)	Heat sink to ambient temperature rise T _{hs-amb} (°C)
		GooLED-LUME-7830	
5.0		4.80	24.0
10.0		3.60	36.0
15.0		3.13	47.0
20.0		2.95	59.0
25.0		2.72	68.0

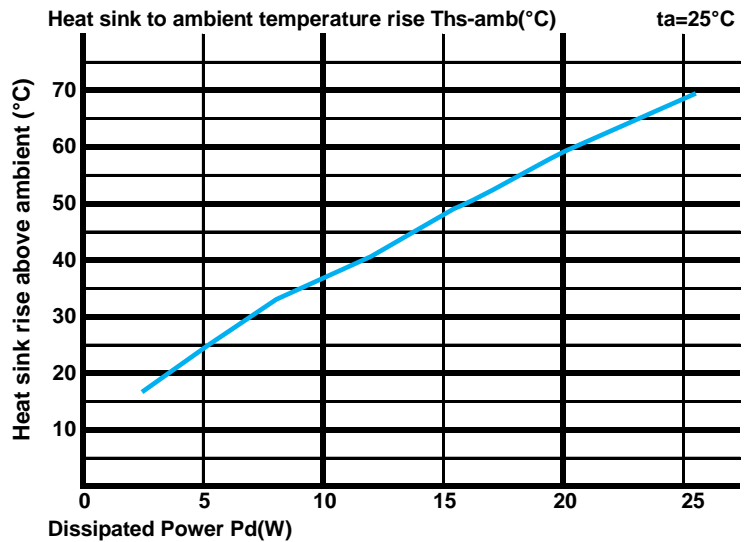

*The aluminum substrate side of the package outer shell is thermally connected to the heat sink via TIM (Thermal interface material).

MingFa recommends the use of a high thermal conductive interface between the LED module and the LED cooler.

Either thermal grease, A thermal pad or a phase change thermal pad thickness 0.1-0.15mm is recommended.

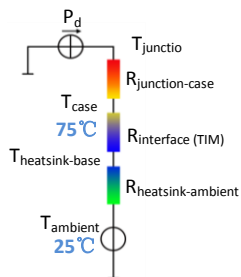

*Thermal resistance is a heat property and a measurement of a temperature difference by which an object or material resists a heat flow.

Geometric shapes are different, the thermal resistance is different. Formula: $\theta = (T_{hs} - T_a) / P_d$

θ - Thermal Resistance [°C/W]; T_{hs} - Heatsink temperature; T_a - Ambient temperature;

*The thermal resistance between the junction section of the light-emitting diode and the aluminum substrate side of the package outer shell is R_{junction-case}, the thermal resistance of the TIM outside the package is R_{interface (TIM)} [°C/W], the thermal resistance with the heat sink is R_{heatsink-ambient} [°C/W], and the ambient temperature is T_{ambient} [°C].

*Thermal resistances outside the package R_{interface (TIM)} and R_{heatsink-ambient} can be integrated into the thermal resistance R_{case-ambient} at this point. Thus, the following formula is also used:

$$T_{\text{junction}} = (R_{\text{junction-case}} + R_{\text{case-ambient}}) \cdot P_d + T_{\text{ambient}}$$