

# Shaded Pole Motor Fan

罩極電機風扇

# 120mm



- 1 Frame**  
Aluminium alloy die-casting, surfaces is finished by black anti-corrosion treatment.
- 2 Impeller**  
Black plastic PBT UL94V-0
- 3 Operation Temperature/Humidity Range:  
(under unconcretionary state)**  
-30°C ~ +60°C (temperature), 0% ~ 95% (himidity)
- 4 Protection**  
Impedance Protected
- 5 Withstand Voltage**  
AC 1,800V, 1 min at 0.5mA, 50/60 Hz
- 6 Insulation System**  
design according to IEC61858 Grade B,
- 7 Protection Grade** IP34

- 1 機 架:**  
合金鋁壓鑄成型，表面黑色抗腐蝕處理
- 2 風 葉:**  
黑色塑料 PBT UL94V-0.
- 3 運行溫/濕度範圍: (非凝結狀態)**  
溫度 -40°C ~ +65°C 濕度 0% ~ 95%
- 4 保 護:**  
阻抗保護
- 5 絕緣耐壓:**  
AC 1800V 0.5mA 50/60Hz下耐受1分鐘
- 6 絕緣系統:**  
按 IEC61858 B級設計
- 7 電機防護等級:**  
IP 34

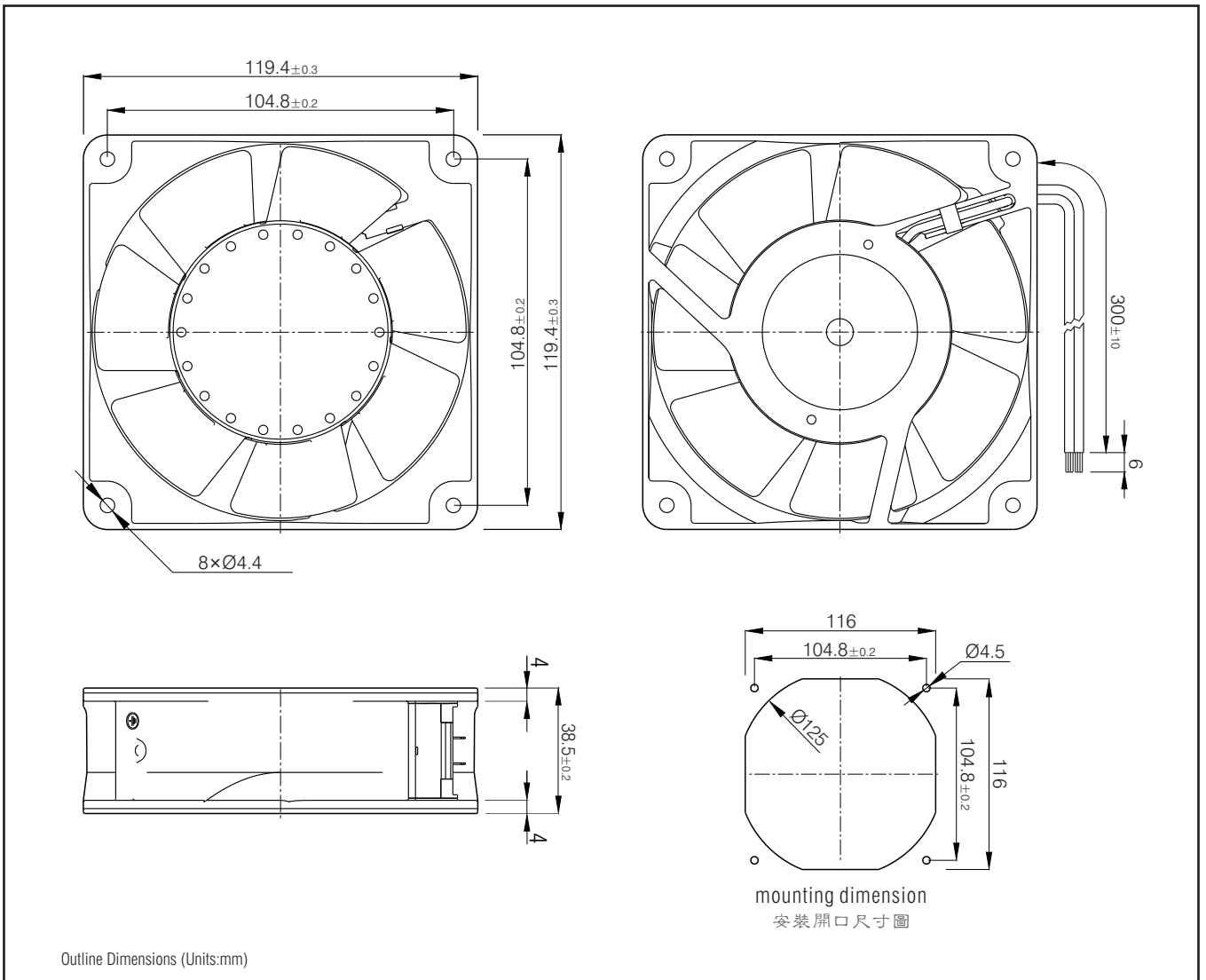

- Ⓐ Rotation direction of blades : CCW seen from the front impellers
- Ⓑ Power Connection: UL3385-22 Lead wire, (terminal connction)
- Ⓒ Unit weight: 510g

- Ⓐ 風扇旋向：從扇葉方向看為逆時針
- Ⓑ 電源連接：UL3385-22 引線連接 (插片連接)
- Ⓒ 單機重量：510g

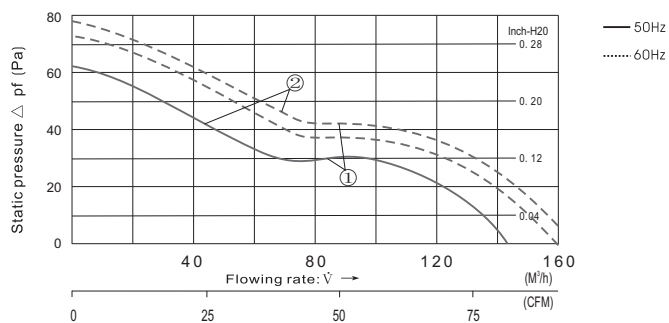

## Parameters

Type 產品型號	Motor 電機	Rated Voltage 額定電壓 V	Frequency 周波數 Hz	current 電流 (A)	Power 功率 (W) <small>+10% -20%</small>	Speed 回轉速度 (min <sup>-1</sup> )	Max Air Flow 最大風量 CFM    m <sup>3</sup> /h	Static Pressure 最大靜壓 (Pa)	Noise 噪音 (dB)	Curve 曲綫	Capacitor 電容 (μF)
FJ12031AS	M2S6301-SB	115	50	0.24	18	2500	85    145	51	34	Ⓐ	----
			60	0.20	15	2800	100    170	63	37		
FJ12031AB	M2S6301-AB	115	50	0.24	18	2500	85    145	51	34	Ⓑ	----
			60	0.20	15	2800	100    170	63	37		
FJ12032AS	M2E6301-SB	230	50	0.12	19	2500	85    145	51	34	Ⓐ	----
			60	0.10	14	2700	95    160	63	37		
FJ12032AB	M2E6301-AB	230	50	0.12	19	2500	85    145	51	34	Ⓑ	----
			60	0.10	14	2700	95    160	63	37		
FJ12033AB	M2D6301-AB	380	50	0.07	18	2500	85    145	51	34	Ⓐ	----
			60	0.06	16	2800	100    170	63	37		