

External rotor sickle impeller

外轉子鎌刀形葉輪

Ø400

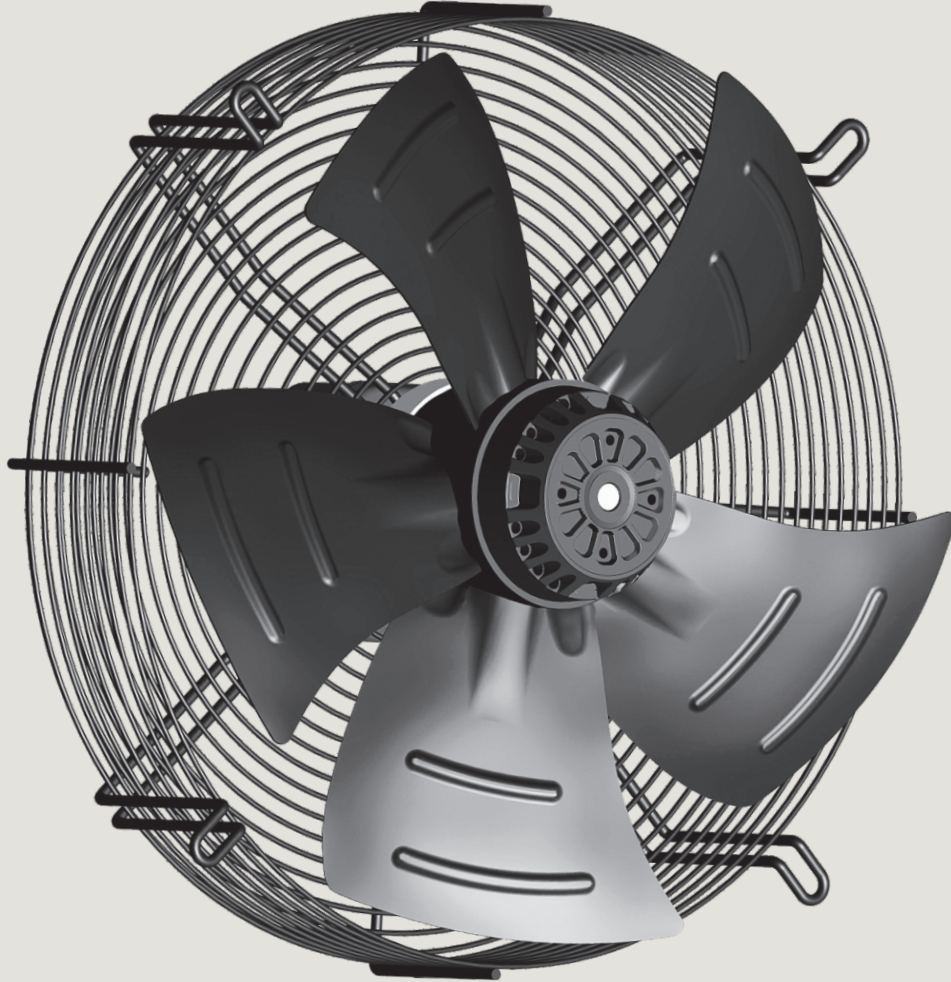

- 1 Motor**
Cage type capacitor start external rotor motor
- 2 Impeller**
Pressed from metal armor plate, impellers are welded to motor rotor and its surface is black and anti-corrosion
- 3 Fixed Guard**
Steel wire is finished with black paint and anti-corrosion treatment
- 4 Allowable environment temperature and humidity range:(under unconcretionary condition)**
-30°C ~ +70°C (temperature) 0% ~ 95% (humidity)
- 5 Protection**
Automatic recovery thermal protection
- 6 Withstand Voltage**
AC 1,800V , 1 min at 0.5mA, 50/60 Hz
- 7 Insulation Grade**
Design according to IEC61858 Grade F,
- 8 Protection Grade** IP44

- 1 電機:**
籠形電容啓動外轉子電機
- 2 葉輪:**
金屬鋼板:沖壓成型, 焊接在轉子上, 表面黑色電泳抗腐蝕處理
- 3 固定網罩:**
金屬鋼絲表面黑色烤漆抗腐蝕處理
- 4 允許環境溫度和濕度範圍:(非凝結狀態)**
-30°C ~ +70°C (溫度) 0% ~ 95% (濕度)
- 5 保護:**
電機內部帶自動恢復熱保護器
- 6 絕緣耐壓:**
AC 1800V 0.5mA 50/60Hz下耐壓1分鐘
- 7 絕緣隔絕等級:**
按 IEC61858 F級設計
- 8 電機防護等級:**
IP 44

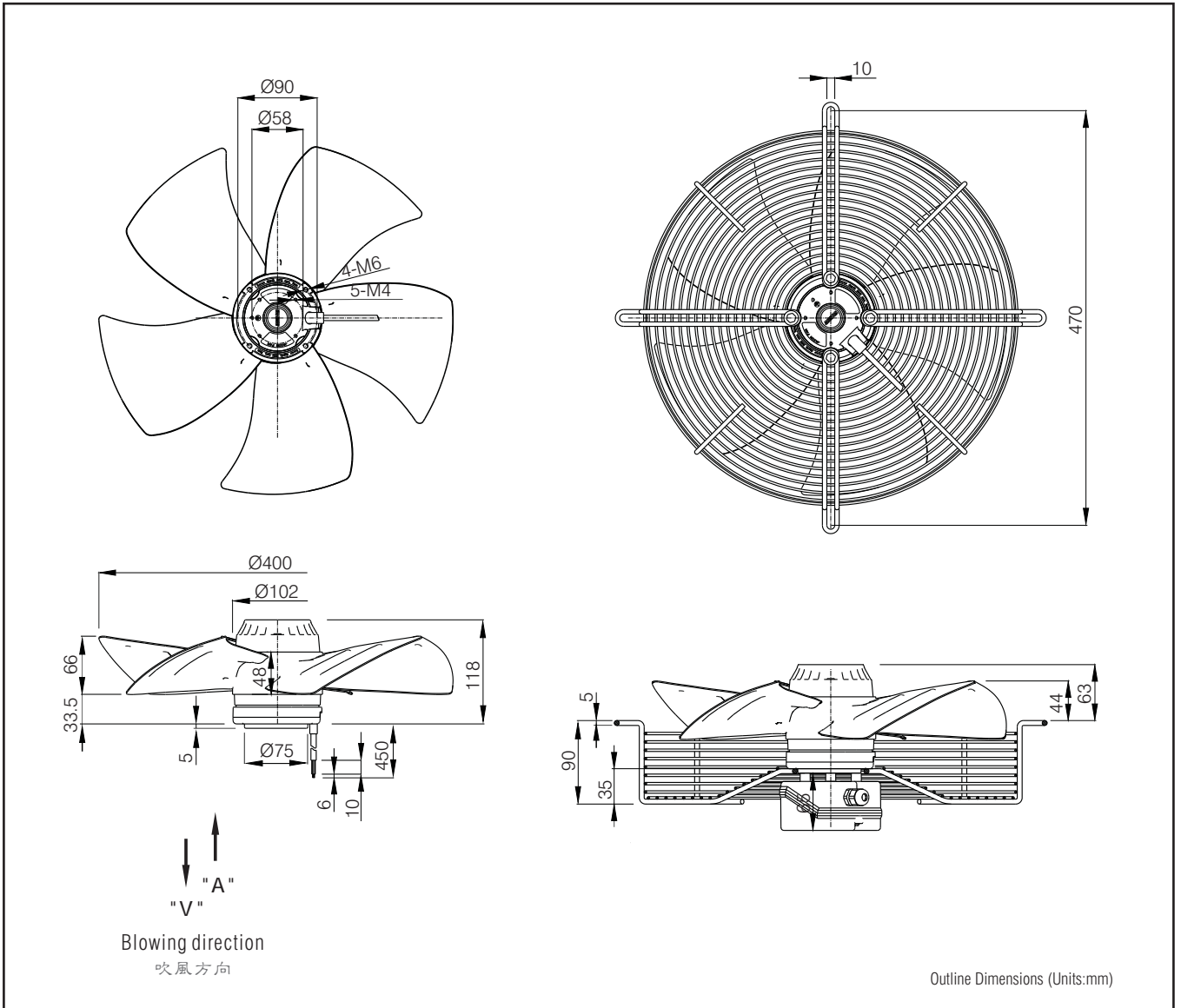

Outline Dimensions (Units:mm)

- Ⓐ Rotation direction of blades : CCW seen from the front impellers
- Ⓑ Power Connection: Lead or terminal box
- Ⓒ Unit weight: 5.5kg

- Ⓐ 風扇旋向：從扇葉方向看為逆時針
- Ⓑ 電源連接：引線或接線盒裝置
- Ⓒ 單機重量：5.5kg

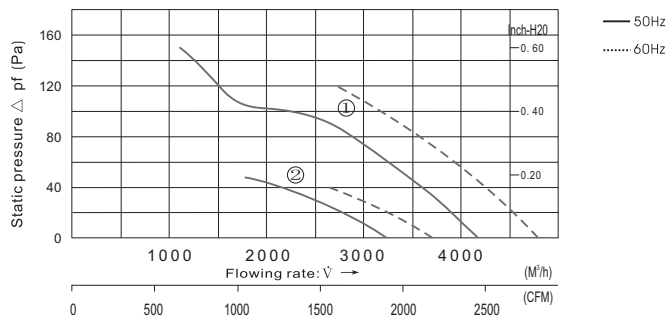

Parameters

Type 產品型號	Motor 電機	Rated Voltage 額定電壓 V	Frequency 周波數 Hz	current 電流 (A)	Power 功率 (W) +10% -20%	Speed 回轉速度 (min ⁻¹)	Max Air Flow 最大風量 CFM m ³ /h	Static Pressure 最大靜壓 (Pa)	Noise 噪音 (dB)	Curve 曲線	Capacitor 電容 (μF)
FJ4S-400.FGV	M4S10202-AF	115	50	1.90	196	1400	2440	4140	150	68	Ⓐ 20.0/250
			60	2.18	248	1600	2750	4660	120	71	
FJ4E-400.FGV	M4E10202-AF	230	50	0.80	175	1400	2440	4140	150	68	Ⓐ 5.0/450
			60	1.00	250	1600	2750	4660	120	71	
FJ4ED-400.FGV	M4ED10202-AF	230/400	50	.77/.44	166/167	1400	2440	4140	150	64	Ⓐ -----
			60	.75/.43	226/225	1600	2750	4660	120	68	
FJ6D-400.FGV	M6D10202-AF	400	50	0.21	68	920	1900	3220	50	71	Ⓑ -----
			60	0.19	82	1050	2170	3680	40	60	